

CB 24 MANUAL CONTROL

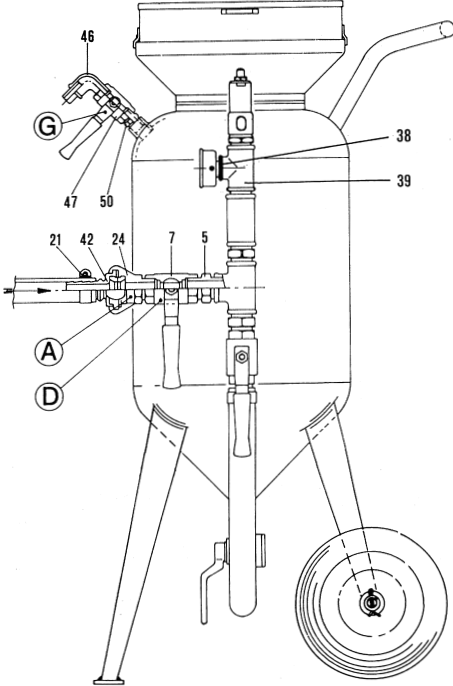

Model:
CB 24
Maximum work
pressure:
7 bar
Abrasive capacity:
lt. 24
Height:
cm. 84
Diameter:
cm. 63
Tare
weight:
kg. 32

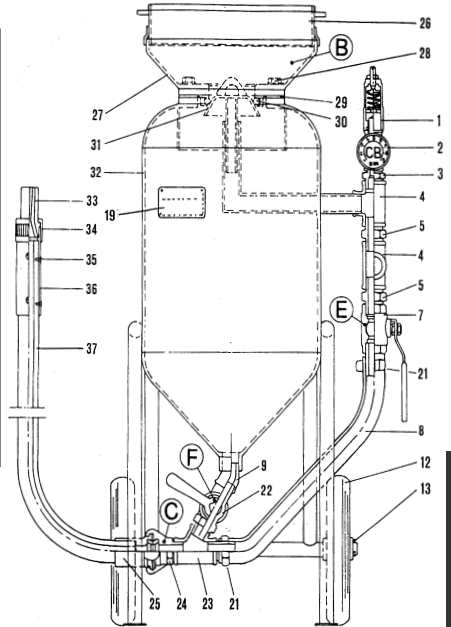

ENGLISH

1	V 0006	Safety valve	26	V 0225	Sieve
2	V 0202	Manometer for pressure control of abrasive container	27	V 0023	Funnel cover
3	V 0203	Reduced nipple 3/4 - 3/8	28	V 0227	Cover fixing screw
4	V 0007	T-joint	29	V 0004	Gasket for cover
5	V 0008	Nipple	30	V 0005	Gasket for closure head
7	V 0009	Air batcher valve	31	V 0022	Closure head
8	V 0012	Conjunction extension	32	V 0021	Abrasive container
9	V 0015	45° curve	33	UG 1	Nozzle (see nozzle table)
12	V 0013	Wheel	34	V 0232	Nozzle fixing bush
13	V 0014	Cotter pin	35	V 0233	Handle fixing screw
19	V 0403	Plate	36	RA 10	Nozzle holder
21	V 0011	Nipple 3/4 A.P.	37	TU 1	Tube for abrasive
22	V 0016	Abrasive batcher valve	38	V 0236	Reduction 3/8 - 1/4
23	V 0017	45° t-joint	39	V 0238	T-connection 3/8
24	RA 3	Fast hooking connection	46	V 0024	Crank 3/8
25	RA 13	Sand tube connection	47	V 0025	Air exhaust valve 3/8
			50	V 0026	Nipple 3/8