



# SUPER PRO EVO

TAGLIAPIASTRELLE PROFESSIONALE

**TRASPORTO**

Maneggevole e facile da trasportare.

**IMBALLO**

Imballo flessografico multilingue.

	Art. 35125	Art. 3590	Art. 3565
LUNGHEZZA DI TAGLIO	1250 mm	900 mm	650 mm
FORM. MAX PIASTR. PER TAGLIO IN DIAGONALE	884x884 mm	636x636 mm	460x460 mm
SPESSORE DI TAGLIO	4 - 18 mm		
DIAMETRO ROTELLA	Ø 22 x 6,1 x 4,7 mm		
DIMENSIONE IMBALLO	1600x300x 210 mm	1250x300x 210 mm	1000x300x 210 mm
NUMERO PEZZI PER PALLET	20	30	40
DIMENSIONI PALLET	720x1750x 2250 mm	900x1250x 2250 mm	1200x1000x 2250 mm
PESO	11,5 Kg	9,5 Kg	8 Kg



RIVENDITORE AUTORIZZATO



Z. i. 2 - Via Cavatorta, 6/1 | 48033 Cotignola (Ra) | ITALY  
[www.battipav.com](http://www.battipav.com) | [vendite@battipav.com](mailto:vendite@battipav.com)



Ottobre 2020

**BATTIPAV**™

MACCHINE PER EDILIZIA | MACHINES FOR BUILDING



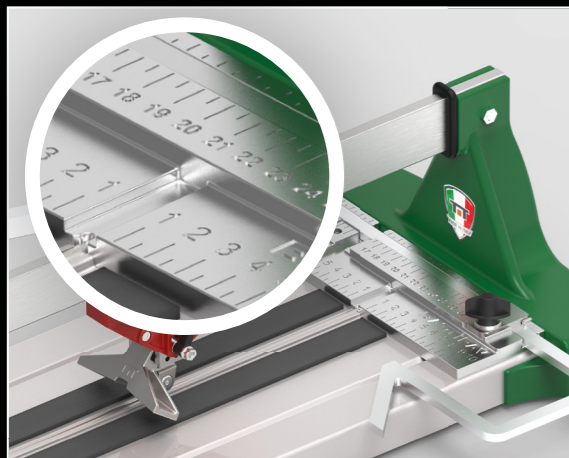

**SUPPORTO PIASTRELLA**

Realizzato in alluminio con scala millimetrica visibile.

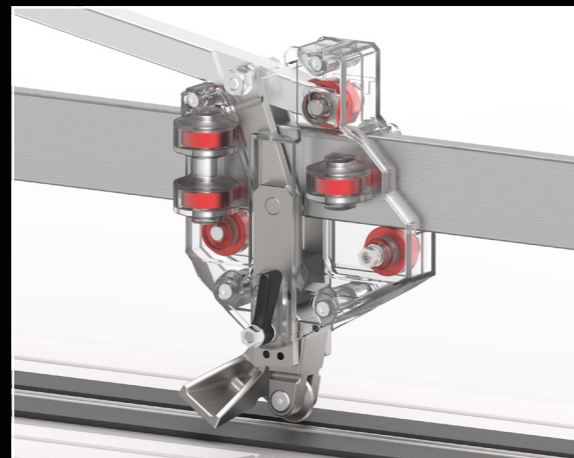

**CARRELLO**

Costituito da 9 cuscinetti a sfera, 4 dei quali registrabili, per un perfetto scorrimento.

**STRUTTURA**

In alluminio trafilato per avere il massimo della solidità e, nel contempo, leggerezza.



**PRECISIONE E LEGGEREZZA**

**SISTEMA DI TAGLIO A SPINTA**

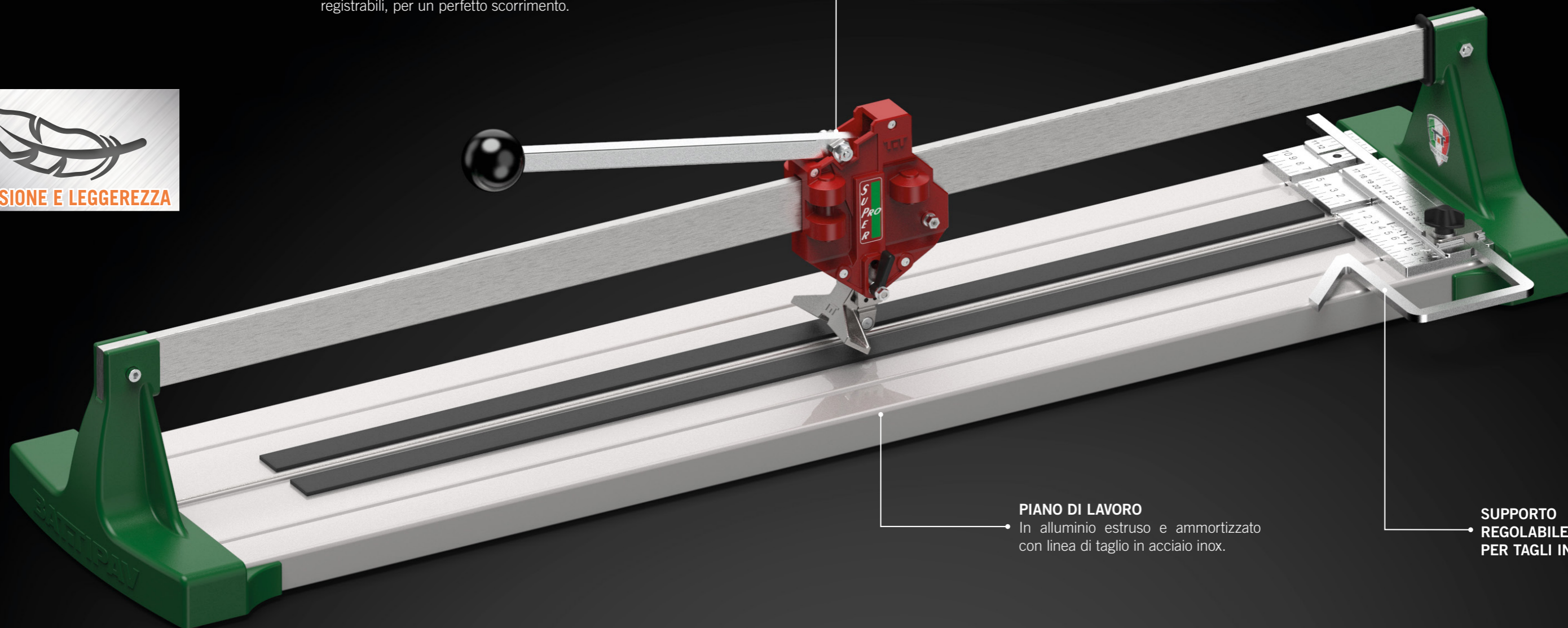

**PIANO DI LAVORO**

In alluminio estruso e ammortizzato con linea di taglio in acciaio inox.

**SUPPORTO REGOLABILE PER TAGLI IN SERIE**



**TAGLI DRITTI**

Squadretta con lettura diretta per tagli dritti.



**TAGLI DIAGONALI**

Squadretta con lettura diretta per tagli diagonali.